

Hello There.

Let's Help Get You Started.

Storage S2 Installation Manual

AIO-10KWH1P2S-CE

Inverter: AIO-10KWH1PINV-CE

Battery: AIO-10KWH1PBM-CE

Release Version: 4.3



Hello There.
Let's Help Get You Started.

Storage S2 Installation Manual

AIO-10KWH1P2S-CE

Release Version: Version 4.3

Contents

1. Statement and Declaration

1.3. Product Model Description

- -

Operation Modes Introduction

- -
- -

3 Preparation Before Installation

2 Check Before Unpacking

3.4 Installation Tools Preparation

Installation Requirements

4.1.1 Unacceptable Installations

4.2.1 Ensure a Flat Installation Surface

4.2.2 Get the Battery Module Stacked

-
4.8 Protective Cover Connection

-
5 After Installation Checklist

5.3 Install the LAVO Storage S2 Applications

6 Storage and Maintenance

.1.3 Fire Retardant Buildings

7 Safety, Regulation & General Service

1. Statement and

unit primarily consists of two components: a hybrid inverter and a variable number of battery modules. The number of battery modules can range from 1 to 4, while the hybrid inverter can also operate independently without any battery modules. However, the inverter was not tested to Section 5 of AS/NZS 4777.2:2020 for multiple inverter combinations and/or multiple phase inverter combinations. Therefore, such combinations should not be used, or external devices should be utilised in accordance with the require

The battery modules (AIO- -CE) are only compatible with the hybrid -CE). More details on parameters, please go to "8.3. Product Parameters".

The pictures in this manual are for reference and may differ slightly from the final products due to updates. The content may also be periodically updated or revised without notice. Without special agreement, the document content cannot replace precautions in the product label.

In this document, you can get valuable product messages including product , installation, electrical cable connection, after-installation check, storage, and cycle maintain, emergency measures and typical troubleshooting.

Please read this manual carefully before any operations. The authorised personnel should be familiar with the file content to know about the product features, functions and safety and electrical precautions.

Please keep this manual readily available in case of an emergency. Do not operate the product before reading through.

Professional and experienced industrial workers who understand the relative local laws and regulations that can conduct installation and product maintain in a suitable

1.3. Product Model Description



LAVO and other LAVO signs are trademarks of LAVO Hydrogen Storage Technology Pty Ltd. All other trademarks or registered trademarks mentioned in this manual are owned by cooperate partners.

under the copyright of LAVO Life Pty Ltd with all rights reserved. Please keep it properly and follow the operational instructions strictly. No modification or reproduction should be done without permission.

1.6 Limitation of Liability

LAVO shall not be liable for any repercussions, such as battery damage or property loss resulting from force majeure occurrences during the normal use and storage by the customer or from actions that deviate from the instructions below:

- No modification should be done on the product including, but not limit to disassembling, altering or reproducing.
- Only individuals who have been authorised, trained, tested and certified are permitted to perform standard product operation including installation and cyclic maintenance, in accordance with relevant local regulations.
- Do not attempt to hit, drag, pull, squeeze, crush, drop, penetrate on the product or give weight in any ways.
- Do not immerse the product in water.
- Do not try to heat the product.
-
- Do not disassemble the battery modules or try to access the battery cells.
- Do not put anything into the product.
- Power off before normal repair and maintenance.

- Any defect that is unable to be detected by the existing technology at the time a product enters the market.
- Please carefully read through these instructions before installation and use.

The latest version contains all the updates.

	- -	Performance, Battery Module:
	- -	Product Appearance Update: SOC removed from BM to
	- -	-device parallel support, RCD relative,
	- -	1. Layout of functional ports on PCS Update: System (PCS Electric) Connection Diagram
	- -	Minimum installation distance from heat source in 4.1 the installation requirement table; Data of depth of discharge in 8.3
	- -	Revise the statement and declaration for product details; Add recommended breakers (RCBO/RCD) in 5.7 and update the diagram accordingly; Update the parameters in section 8.3; Operation Modes Introduction; Update System (PCS Electric) Connection Diagram
	- -	3.4 Installation Tools Preparation; Minimum installation distance

		<p>7 Safety, Regulation & General Service;</p> <p>- -</p> <p>Operation Modes Introduction</p> <p>8.1 Emergency Measures and combine with 7 Regulation & General Service.</p>
	- -	
	- -	
	- -	

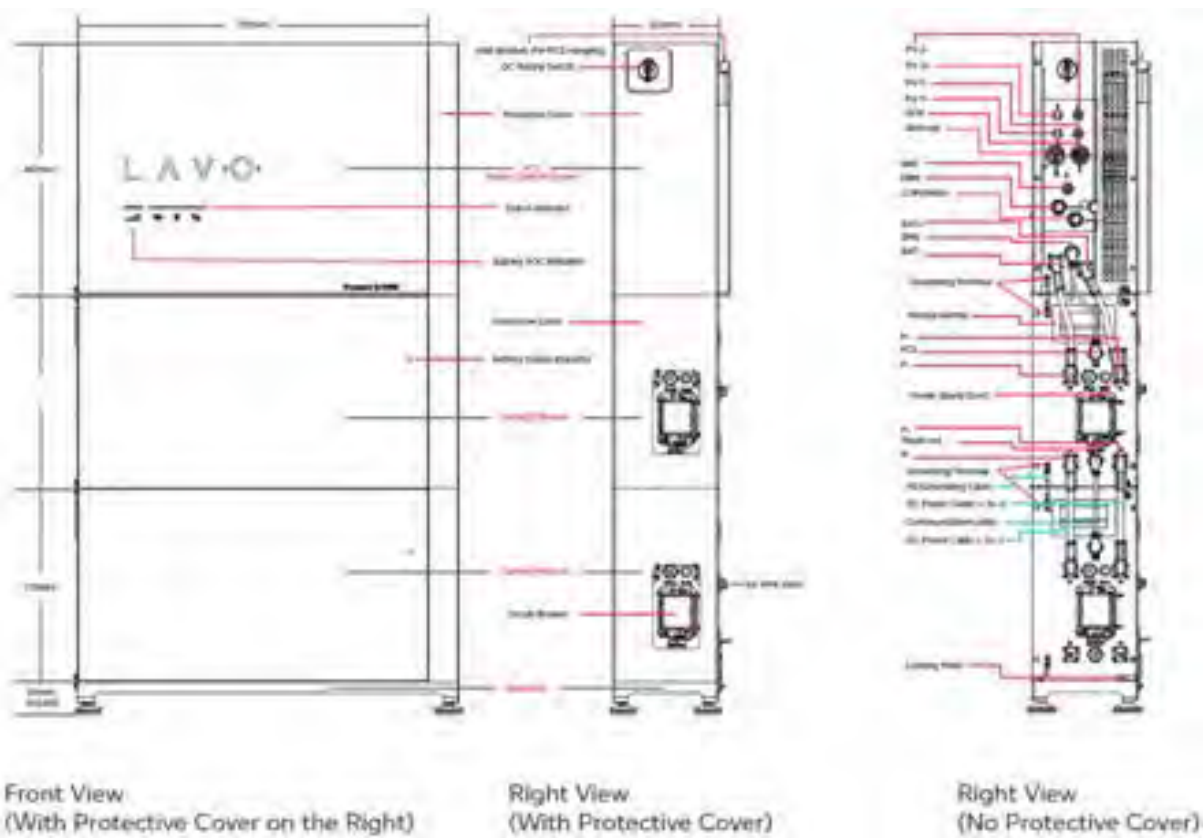

- -CE series is designed with BACK-UP versions for customer to choose based on the local rules.



Please control the home loads and make sure it's within the "BACK-output rating" under BACK- otherwise the inverter will shut down

Please confirm with the LOCAL grid operator whether there are any special regulations for grid connection.

	-	-	
	-	-	

. Operation Modes Introduction

- -CE series normally has the following operation modes based on your configuration and layout

		-	
-			for any shortfall, and finally fill
		-	The inverter preferentially
	-		
		-	The inverter preferentially

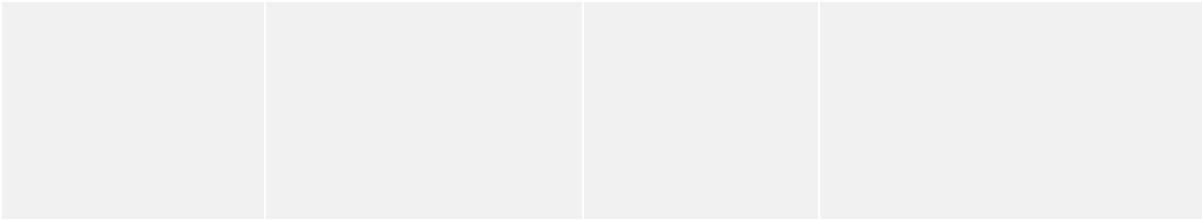

-reverse function is set to enable, when the system is in Peak load shift, or Backup mode, it will not feed power to the grid.

Indicators and Ports



			Communication Port-
	Communication Port-		
	-		







accurate SOC calculation. month to ensure the



	-
	DRM (Demand Response Enabling Communication Port
	BMS Communication Port with Battery
	-

DRM terminal is for Australian only as to meet the local requirement that each PCS should connected with a DRED respectively in a dongle ad-

Status Indicators show the working status of your PV panel, Grod, and the PCS in a power storage and supply system.

		Item/Color	Green	Green Flash	Red
Hybrid Inverter		LB Inverter	Running	Diagnostic/Update	Fault
		Grid	Running	Diagnostic/Update	Fault
		PV Panel	Running	Diagnostic/Update	Fault
Battery		Battery	Running		Fault

DC rotary switch you have on the final product may be different from the picture below in order to meet the requirements of your local regulations.

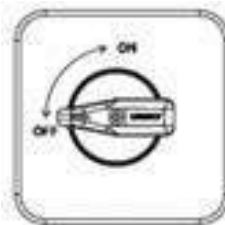

SOC indicator shows the valid capacity of battery

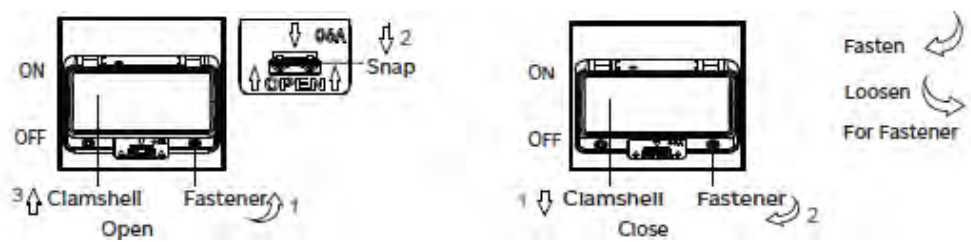
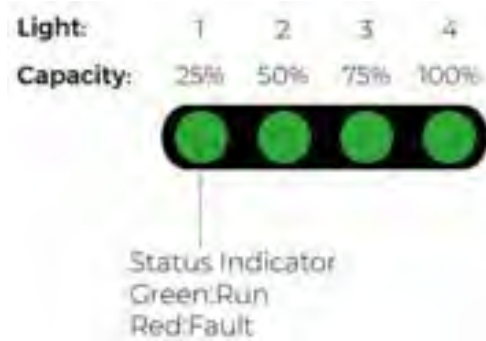

Preparation Before Installation

In this chapter, you will understand the product transportation process, how to unpack the product and some valuable tips for -

The battery module is about kg per unit. Please ensure you have coworkers to support if you are unable to hold or carry the product by yourself to prevent injuries. Please ensure you have appropriate clothing, equipment, and support to carry the product and install as outlined below.

In large scale transportation, hosting tools are suggested.

The product has cleared UN38.3 (Section 38.3 of the Seventh Revised Edition of the Recommendations on the Transport of Dangerous Goods: Manual of Tests and Criteria) and SN/T 0370.2 2009 (Part 2: Performance Test of the Rules of the Inspection of packaging for Exporting Dangerous Goods). The product is classified as class 9 dangerous goods, and shall be transported in accordance with the

- Prohibit piling up with other objects.
- Prohibit mixing up with explosive, inflammable, or toxic objects.
- packaging and keep labels complete and recognisable
- Prevent from direct exposure to sunlight, rain, condensation and mechanical
- -type vehicle including container and metallic van-vehicle and convertible are prohibited.
- Maintain temperature between C, and keep humidity within 95% RH during the storage.
- To ensure the modules are safeguarded against movement, falls or impacts, utilise protective moving equipment such as straps and bubble wrap during transportation. This will help secure the products in position.
- Vehicle in the middle of unloading should berth near dock. Vehicles waiting to be unloaded should keep a safe distance of 6m from warehouse. The vehicle prohibits debris stacking and should stay away from other vehicles.
- Carriers should be equipped with extinguishers designed specifically for lithium batteries, which are used together with fire protection water and sand.









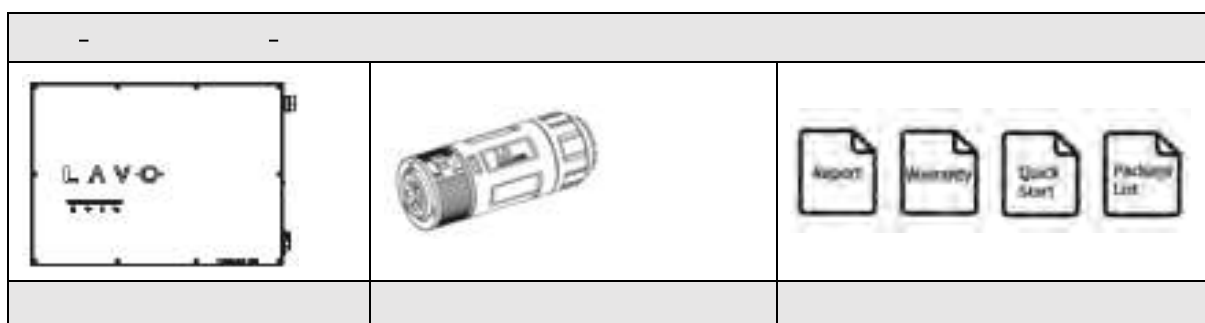









- The transportation must be carried out by trained professionals. All operations during the process must be recorded.
- A damaged box or rattles during transport may indicate a rough handling. Describe the damages on the delivery before signing. If an obvious damage such as package hold or serious impact is found, please contact
- The battery module can only be transported in an upright position.







.2 Check Before Unpacking

the following items before unpacking the product:

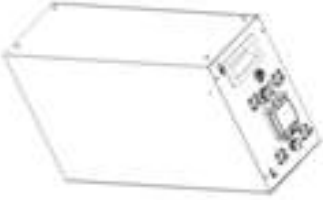
- Check the outer packing box for damage, such as holes, cracks, deformation, and other signs of equipment damage. If any damage is found, do not sign or unpack the package and contact LAVO as soon as possible.
- Check the product messages printed on the packaging. If the product model is not what you requested, do not sign or unpack the package and contact
- After unpacking, check to ensure you have the correct model number, complete contents and the product is intact. Contact LAVO as soon as possible if damage is found.
- Locate the recessed handles on both sides of the battery module and align them horizontally by adjusting their positions.
- Check packing list to make sure you have the required parts.
- Keep product units and spare parts for installation.











		
-	-	Inverter Mounting Bracket*1
 	 	
-	-	-
		
-	-	Expansion Anchor Bolt*5
		
-	Meter (Single Phase)*1	Current Transformer (CT)*1
		
L-	-	-
	-	-
-	-	-





		
Communication Cable*1		
		

Packing List in package box shall take priority as spare parts may already be fixed with product unit that will not be listed.

.4 Installation Tools Preparation

listed below are for reference only, please get more as you need.



			
			

In order to protect the operator and installers' safety, please select and use suitable tools and measuring instruments that are certified for precision and accuracy.

.5 Personal Safety Gear

When dealing with the battery, the following safety gears should be equipped. Installers must meet the relevant requirements of UL or the domestic legislation and other relevant international standards.

Installation

equipment supports a ground-wall mounting type only with clearance from

The space can be reduced as you prefer thus it won't have any influence on product maintenance. Keep the equipment stable to avoid tipping which can result in product damage and personal injuries.

During transportation, turnover, installation and other operations, you must meet the laws, regulations and relevant standards of the country or region where you

Before installation, move the system to the installation site. To avoid personal injury or equipment damage, pay attention to the following:

1. Assign personnel according to the weight of the device. Otherwise, personnel may be injured if the device exceeds the weight that can be carried by the human
2. Wear safety gloves to avoid injury.
3. Ensure that the device is balanced to avoid falling.

Installation Requirements

	Electrical experts or trained and qualified
	Utilise protective equipment and clothing.
	Conduct under the guidance of relative local regulations and
	-
	- -
	Indoor or outdoor (IP65)
	Flat floor surface and a solid wall – only for ground mounting

	Keep the system at least 3m away from heat source ≥ 300mm space around
	Battery specialized fire extinguishers or other devices and materials should be reachable within 5 minutes in
	Do not expose the product directly to sunlight, rain, snow or
	Do not disassemble the product without authori
	Do not hit, drag or jump on the product not immerse the product in water
	Do not heat the product
	Store the product out of reach of children or pets to avoid
	Do not install the inverter in a place with corrosives such as corrosive gas and organic solvent, etc.
	Ensure the installation is not near
	Keep the installation location away from direct cool air
	Avoid installation in areas with potential explosion hazards
	Install away from areas with highly flammable

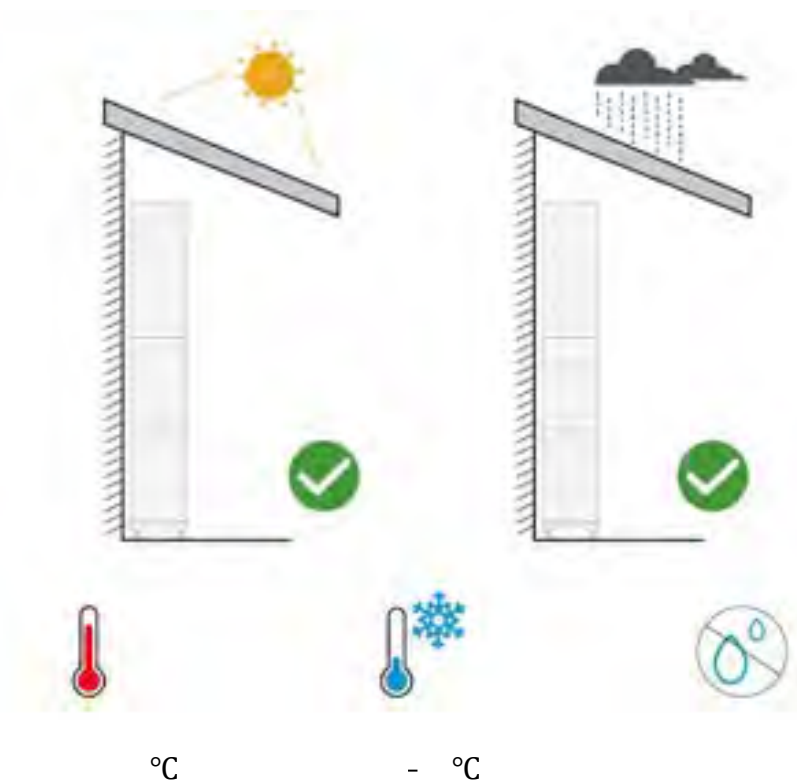

The wall hanging the inverter should meet conditions below:

Solid brick/concrete, or strength equivalent mounting surface;

must be supported or strengthened if the wall's strength isn't enough (such as wooden wall, the wall covered by thick layer of decoration)

Please AVOID direct sunlight, rain exposure, snow laying up during installation and operation.

The slope of the wall should be within $\pm 5^\circ$.

Make sure the installation position does not shake.

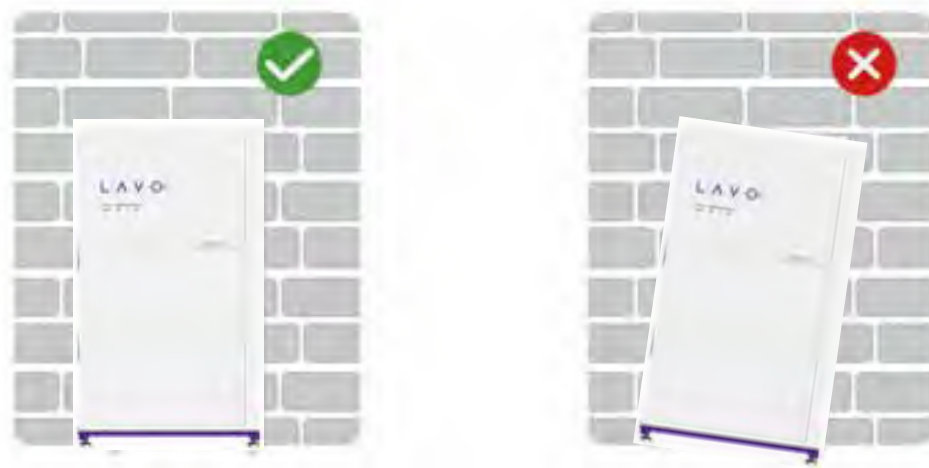

The installation space:



Unacceptable Installations

Please avoid the following installations which will damage the system:

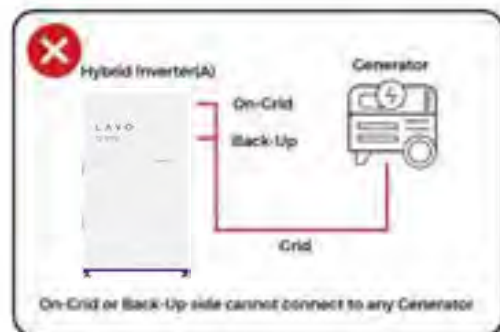
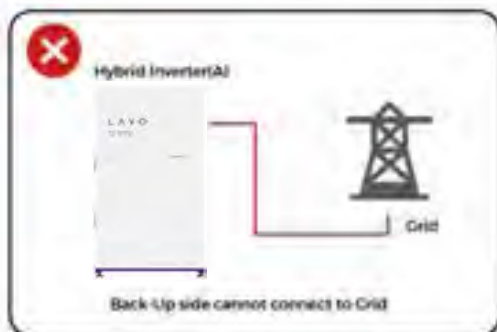
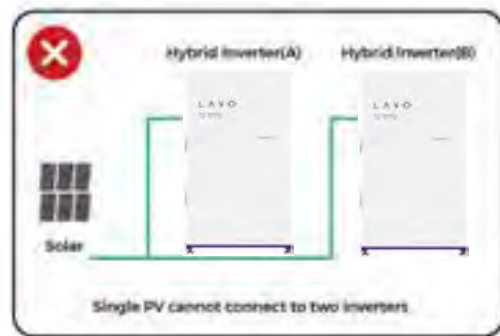
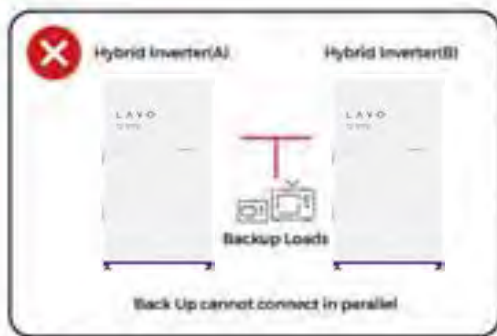

Installation Steps

Ensure a Flat Installation Surface

The product is suggested on a flat floor within less than 8mm per 2 square meters with a wall behind for support and mounting. If the floor smooth, please adjust the adjustable feet to remain install flatness. Adjustable feet screwed under the basement together as a spare part is supplied, packaging together with the inverter.

Get the basement out and make it equipped with adjustable feet with screwdriver if they are not screwed together;

a proper installation location;

Put a horizontal ruler on the basement and adjust the feet until the liquids in the ruler keeps still in the .

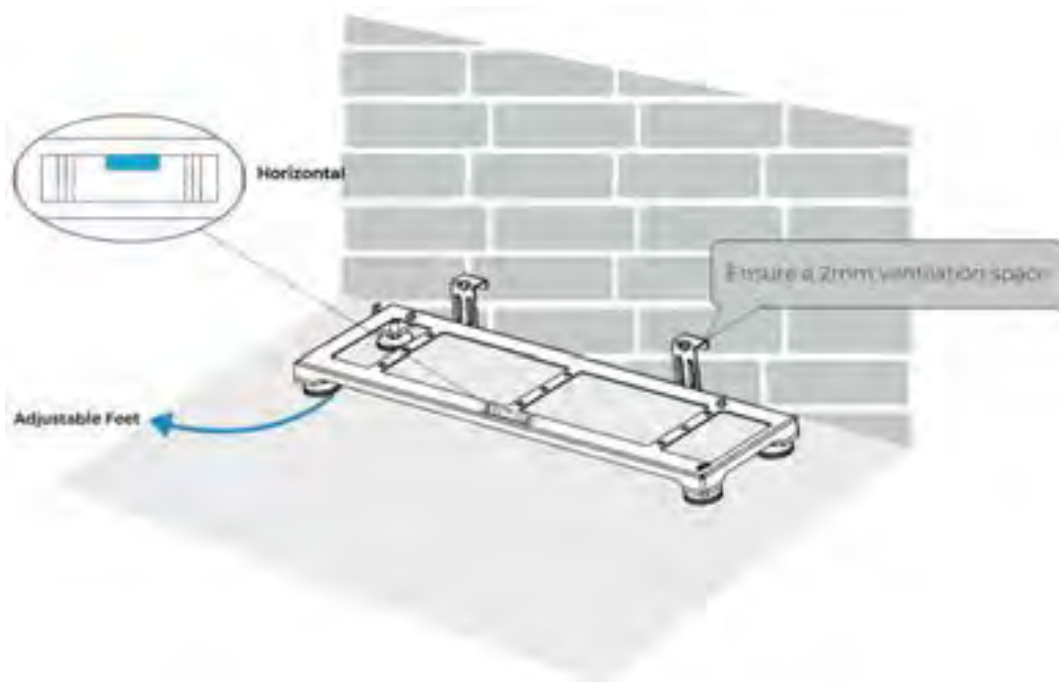

Get the Battery Module Stacked

Put the battery module (a module) on the basement by aligning the positioning pillars (on the Basement) and holes (on the Battery Module);

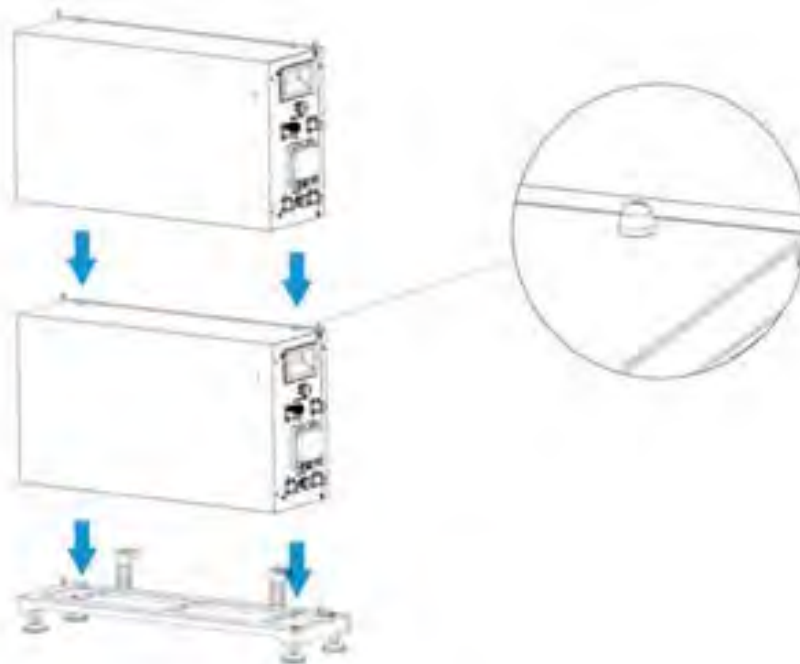

- Fix the module and the basement with a L-shaped mounting bracket;
- Lock the module and the basement together with a locking plate;
- Get other modules stacked by the positioning pillars and holes;
- Lock between modules on both

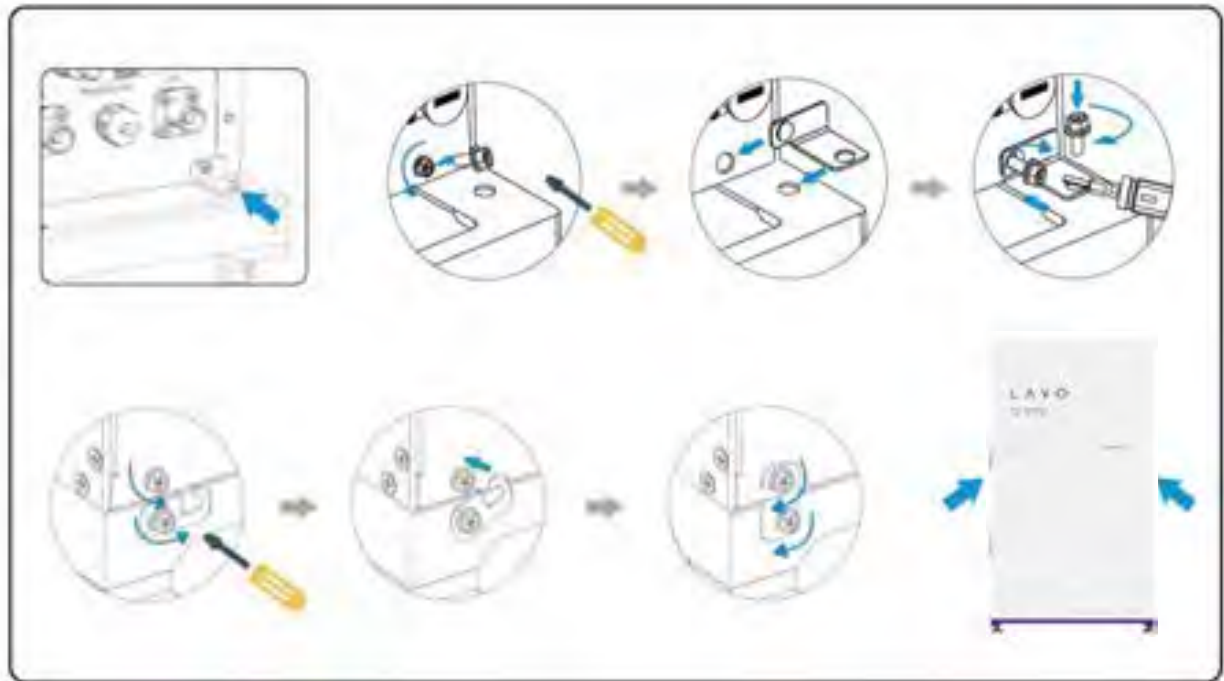

.2.2, we've got the battery modules fixed with the basement in the desired position, now we'll begin with inverter stacking, wall mounting and locking.

Get the inverter wall mounting bracket and the inverter;

Connect the wall mounting bracket with the fixed battery module by aligning the positioning pillars (Battery Module) and holes (mounting bracket);

-

Put the inverter on the mounting bracket;

Lock between the fixed PCS and the battery module with locking plates on

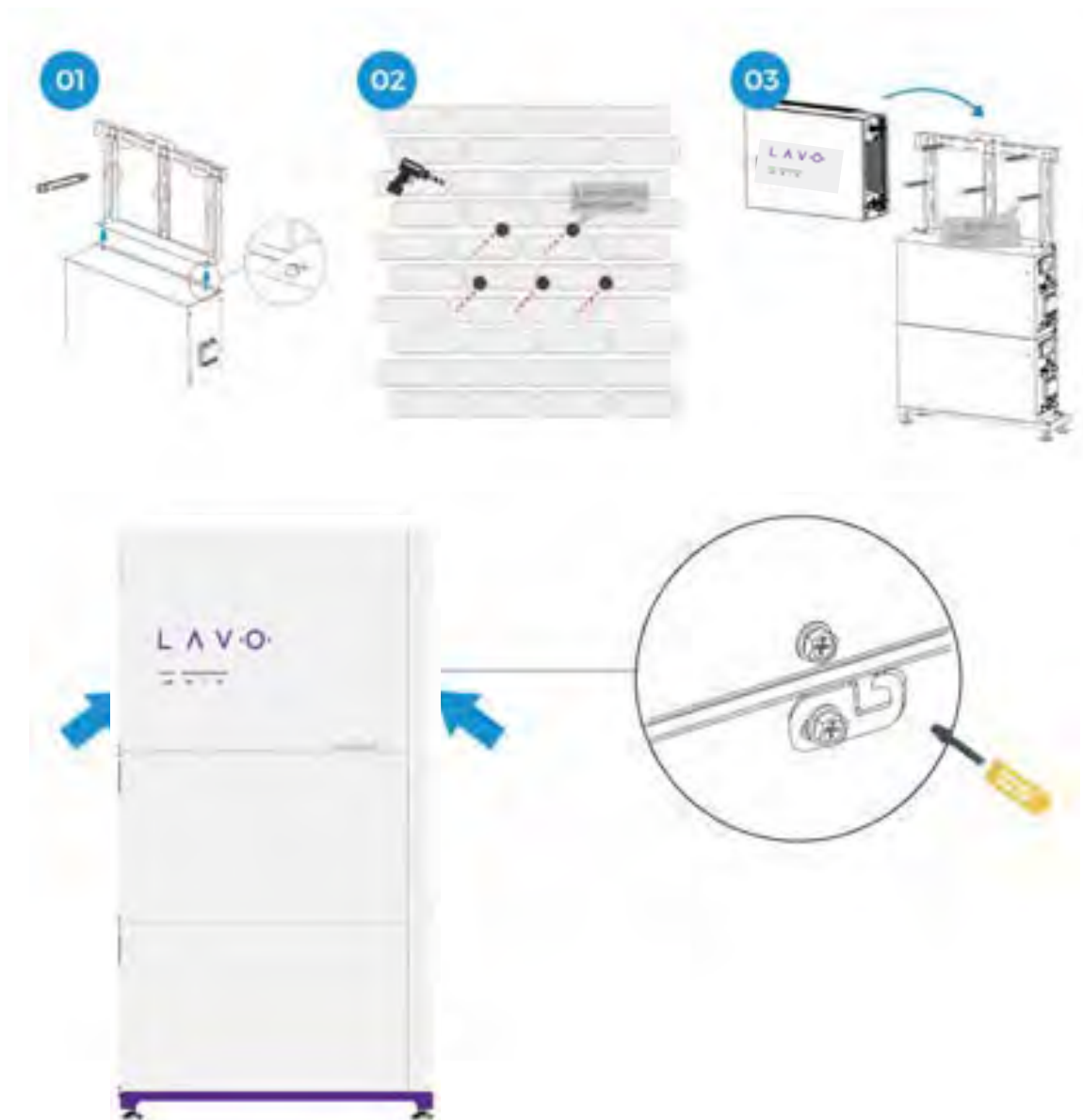

After all the operations above, you've successfully finished the product installation physically, then we will begin with electrical connections in 6.3, please go and follow

. Electrical Connection

connection, turn off the DC switch and AC output switch of the inverter to ensure that the device is powered off. Live operation is strictly otherwise, electric shock and other hazards may occur.

All operations, cables, and components used during electrical connections must comply with local laws and regulations.

If the cable withstands too much tension, the cable may be improperly connected. Reserve a certain length of the cable before connecting it to

making electrical connections, wear personal protective equipment such as safety shoes, protective gloves, and insulation gloves as required.

Only professionals are allowed to perform electrical connection related

The cable colors in the figure are for reference only. The cable specifications must comply with local regulations.

General wiring diagram of system

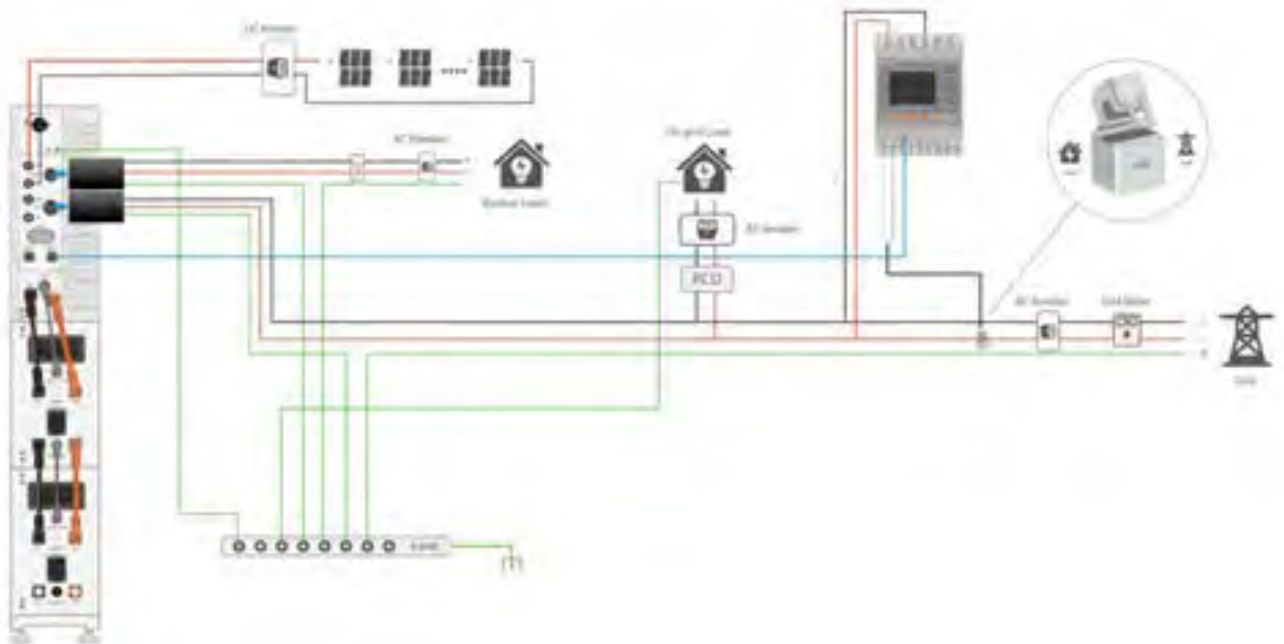

Australia and New Zealand wiring diagram of system

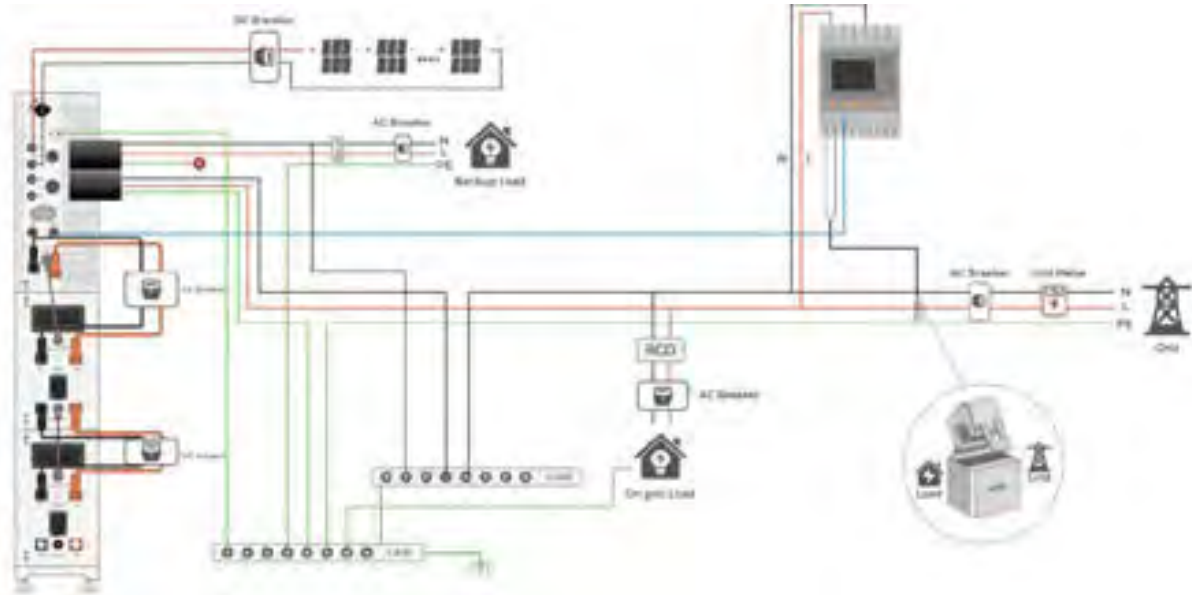

- All switches and RCD devices in the figure are for reference only and the specific installation shall be subject to local regulations!

The arrow on the CT points to the power grid, showing as above. If the CT connector is improperly connected, the inverter cannot read the data correctly, so that the relevant working conditions cannot be realised normally.

The CT must be installed before all loads.

Breakers Recommended:

- Rated Current (Grid On): $\leq 63A$
- -
- Breaking Capacity: $> 3kA$
- -leakage Sensitivity: $30mA$
- -leakage Protection Class: Type A
- - 32U, IIClipsal RCBE 232/30S
- -

It is recommended to utilise a forementioned RCBO or similar ones for installation. Determine whether an AC circuit breaker with greater overcurrent capacity is required based on actual conditions.

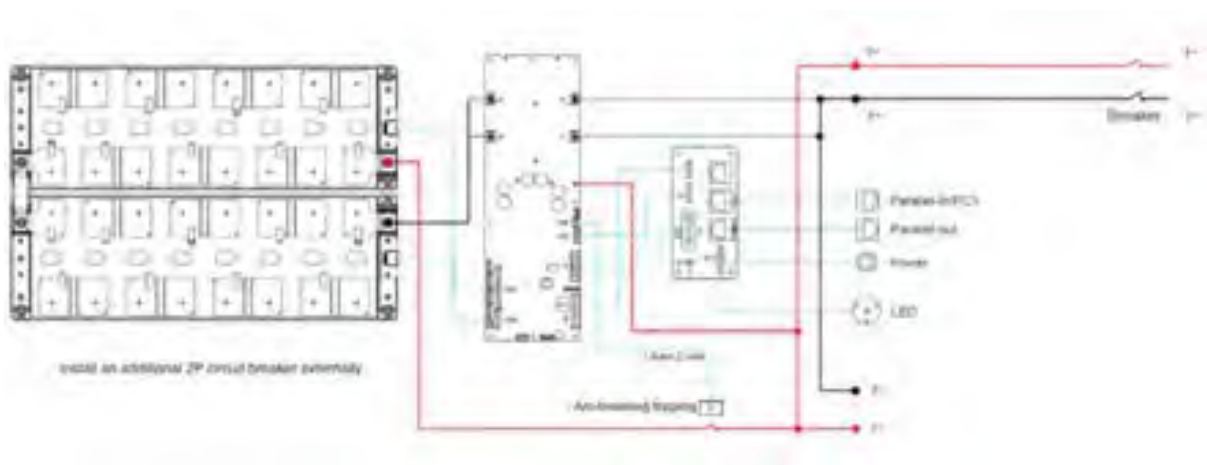

Our battery energy storage system is configured external 2P DC breaker kit including an isolation box for .

Before connection, make sure the DC breaker on the battery is being off, showing

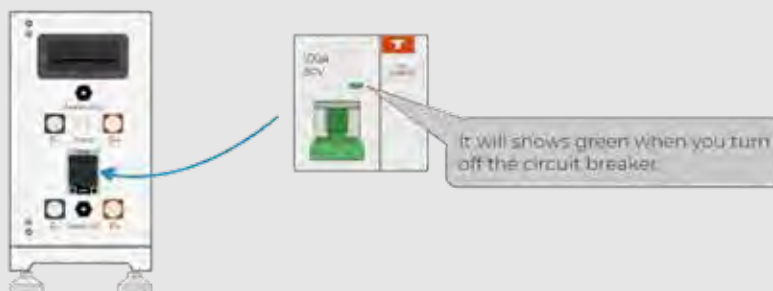

In normal repair or cycle maintenance, after manually powered off the equipment, a multimeter is suggested to ensure that there is no electricity anymore or just

- Confirm the DC rotary switch is off (PCS OFF);
- Confirm the DC breaker switch is down (Battery OFF);
- Connect the communication cables, PE cables and power cables between

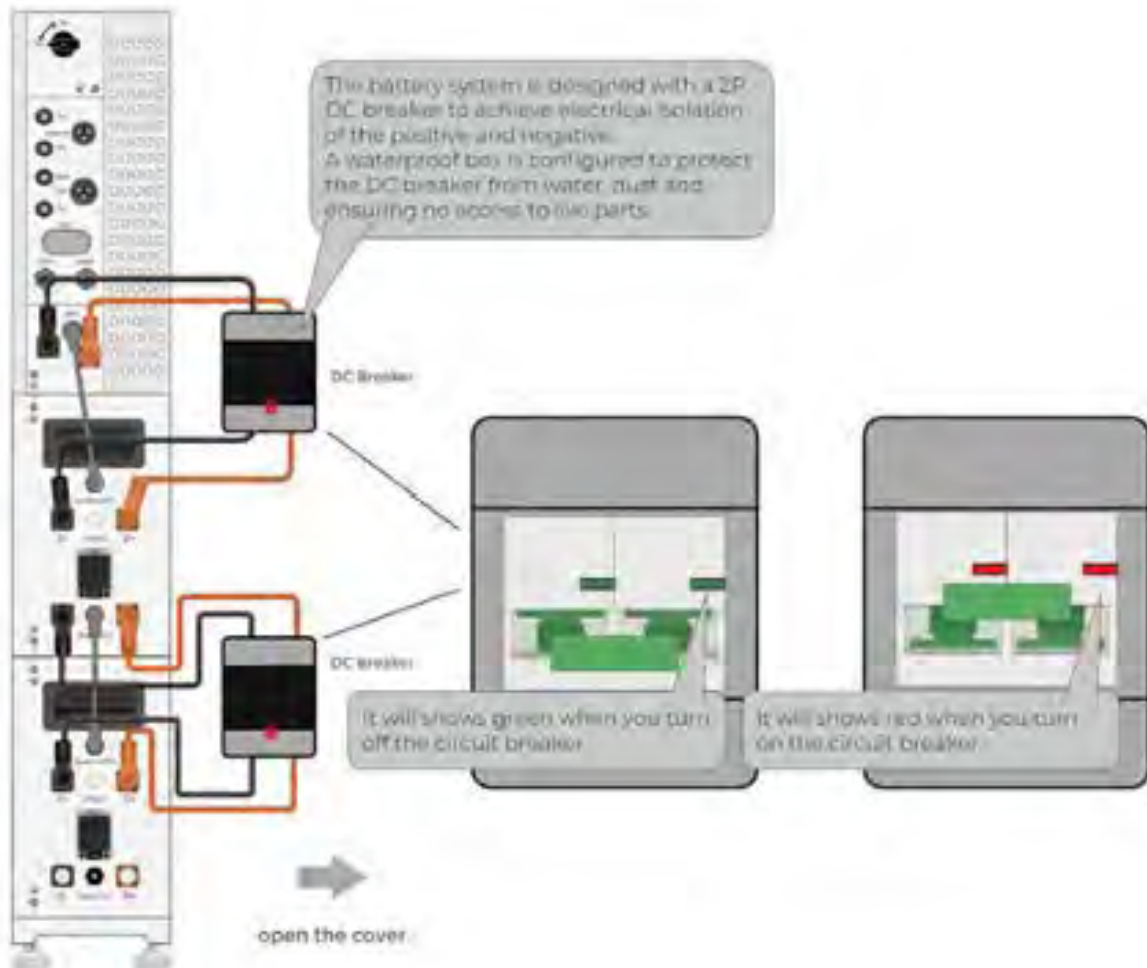
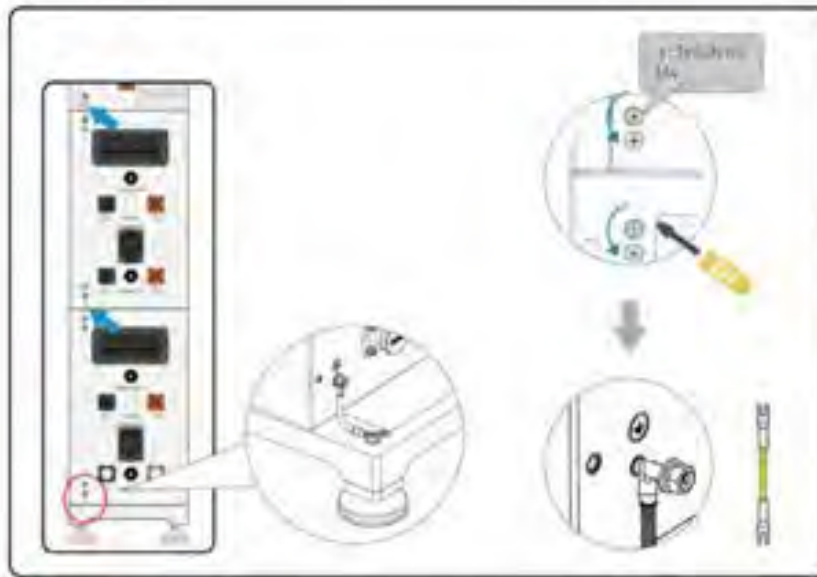

over the terminals that do not have any connections.
 An external DC circuit breaker is . Make sure you connect both the positive and the negative conductors to the 2P DC breaker.

For more safety, it's better to use voltage meter to test the both sides of two poles on the DC breaker and battery positive and negative terminal on the battery pack to check whether there still has voltage, showing like

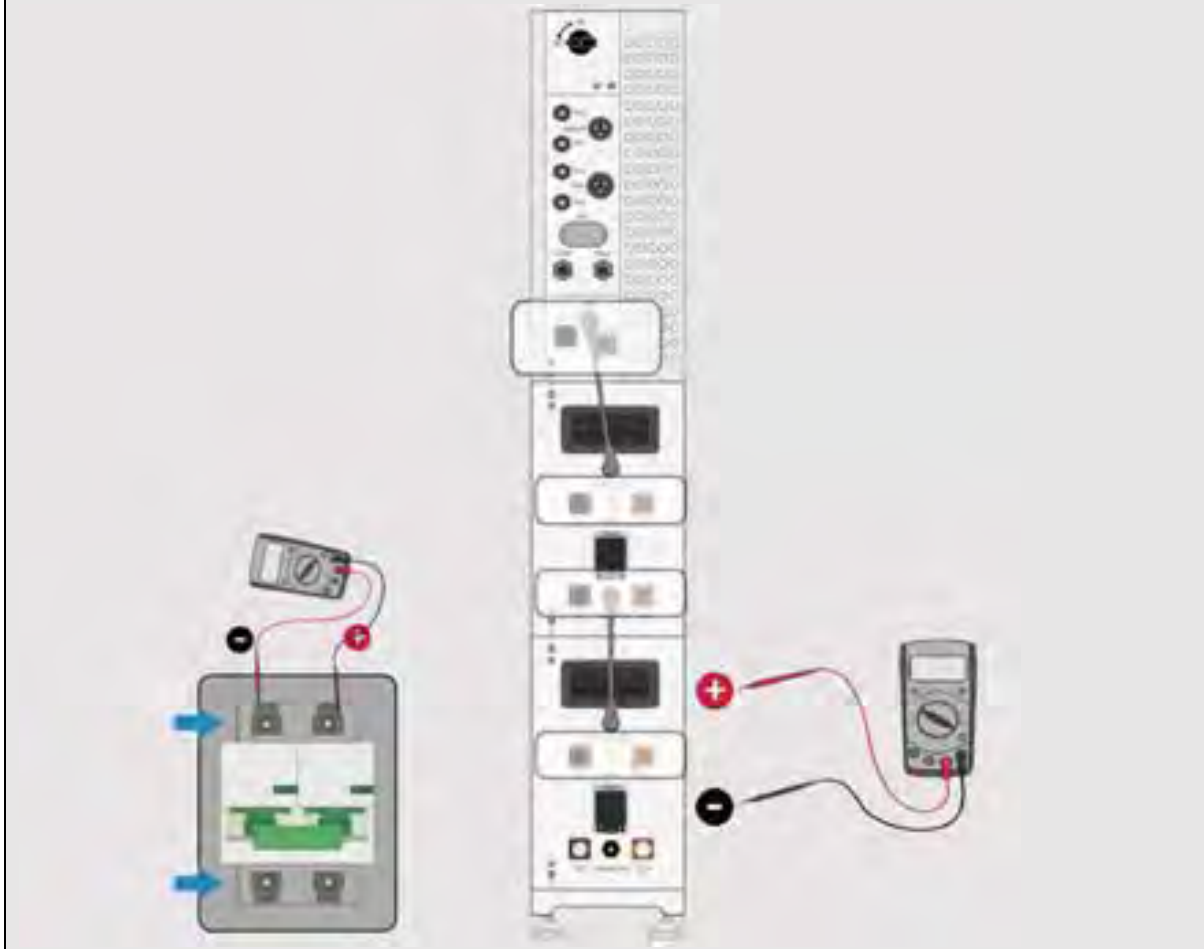

Positive and negative wires are not allowed to reverse.

Hybrid can be connected in series with 2-strings PV modules for inverter. modules with excellent function and reliable quality. - connected in series should be less than Max. DC input voltage; operating voltage should be conformed to MPPT voltage range.

Before connecting PV panels/strings to the inverter, please make sure:

Use the right PV connectors in the accessory box.

The voltage, current, and power ratings of the PV strings are within the allowable range of the inverter. Please refer to the Technical Data Sheet for

voltage and current limits

Make sure the PV switch of the inverter is in the “OFF” position during wiring.
PV strings could not connect to the EARTH conductor.

AWG wire to connect with the cold-
12~15mm of insulation from the end of wire.

Connect PV cables to PV terminals.

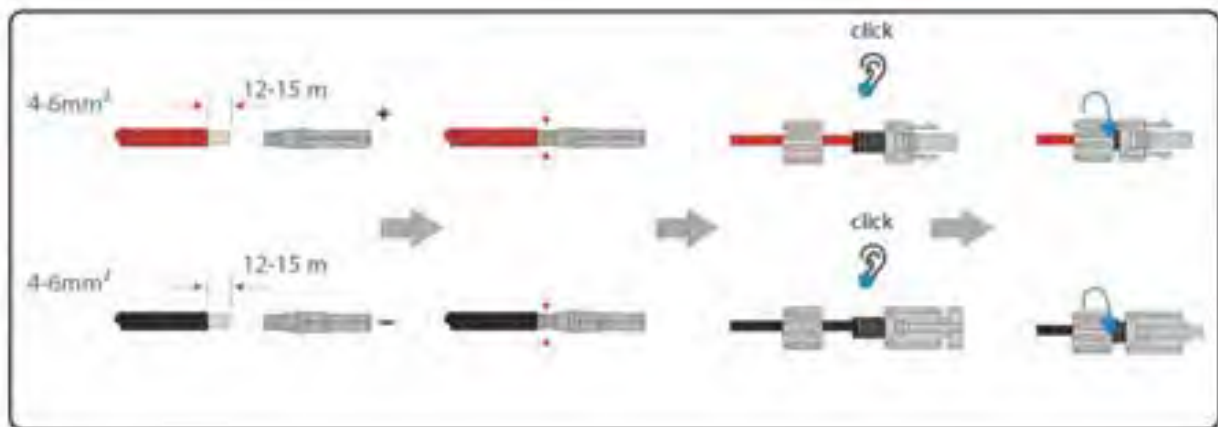

: Check the grid voltage.

Check the grid voltage and compare with the permissive voltage range
(Please refer to technical data)

Disconnect the AC breaker from all the phases.

: Grid cables selection

Use the right pin terminal from the accessory box. Press the connectors on cable

conductor core tightly. (Remove 10mm of insulation from the end of wire.)

	-	-

Cross the Grid cables through the grid port,

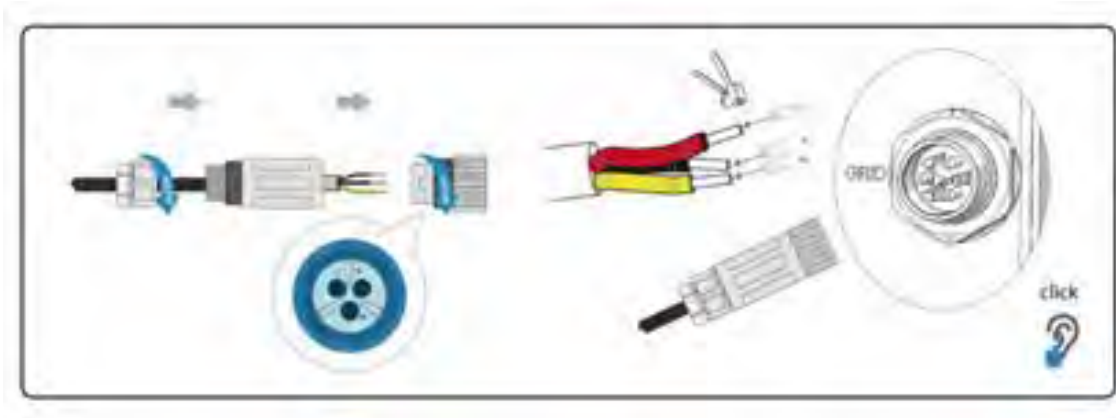

-up: Load Connection

Inverter has On and Off grid function, the inverter will deliver output power through AC port when the grid is on, and it will deliver output power through back-

Load port: important load.

For inverter, the standard PV installation typically consists of the connecting the inverter with both panels and batteries.

2). Hybrid inverters are able to supply overload output as its "Back-please refer to the technical parameters of inverter. And the inverter has self-protection dreading at high ambient temperature.

3). For complicated application, or Special load, please contact after-

In case of discrepancies between wiring mode of local policy and the operation guide above, especially for the wiring of neutral line, grounding, please contact us before any operation!

	-	-

Connect the cables to the BACK-



- -UP load power rating is within BACK- otherwise the inverter will shut down with an “over load” warning.
- When an “over load” is appeared, adjust the load power to make sure it is -UP output power range, then return the inverter.
- For the nonlinear load, please make sure the inrush power should be within -UP output power range.
- You have to enable the EPS function by APP if not, there is no voltage

.

The protective grounding of the shell cannot replace the PGND cable of the AC output outlet. Ensure that the two PGND cables are reliably connected.

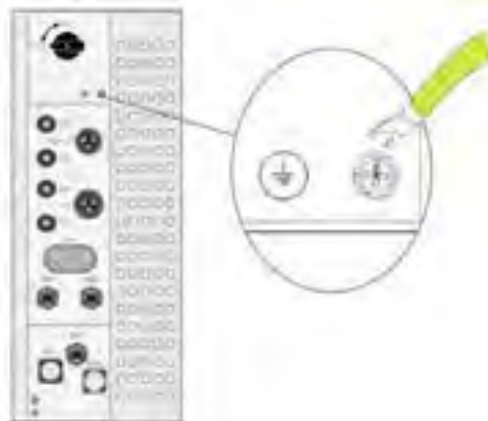

Before installing the protective cover, ensure that all installation, cables, and auxiliary devices are properly installed, and then power on and off to check the operation. If the running check passes, turn off the power supply and install the

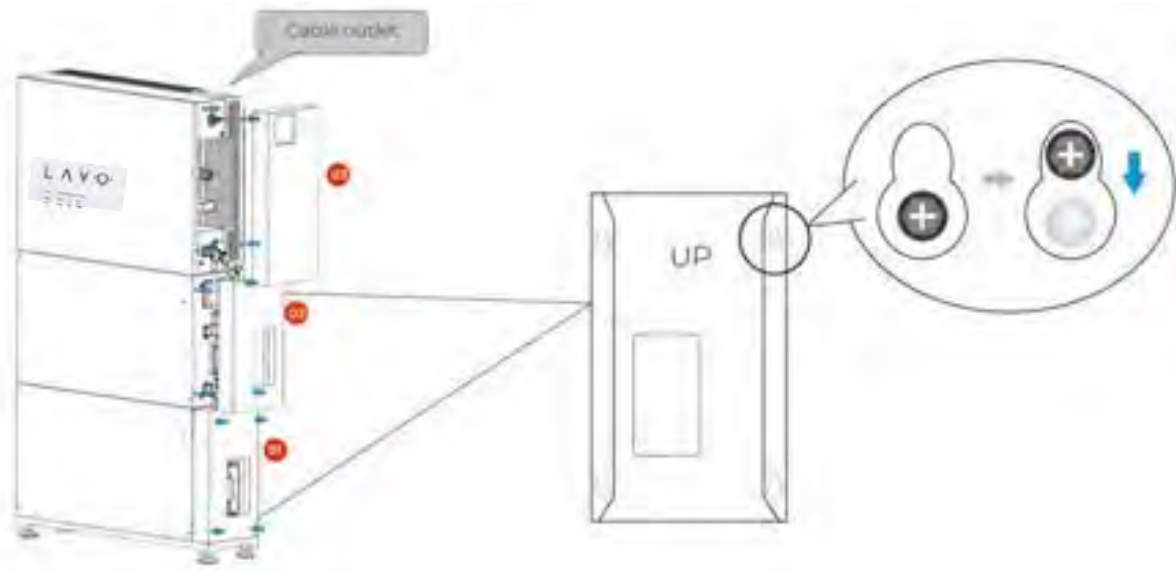

used to detect Grid current.

Get the connector together with RJ45 header in parts bag then unscrew it

Thread the cable through the connector

Strip a distance of 12~15mm

Rearrange the sequence of color-coated copper wires in the standards of

Attach the 8 wires inside the cable to 8 pins in RJ45 header and crimp

Plug into the data port labeled Meter on the PCS firmly

Screw the connector clockwise to fix it on the data port

Connect the cables for meter.



Find the power terminal 1 and 4 (1 for L and 4 for N) on the meter;

Connect the power terminal with a house power supply terminal correspondingly while the cable for connection between the meter and the inverter should be prepared by your own (Cable: 2.5~4mm²/1)

Get the opened CT circle through the grid cable (L) that connecting between the grid terminal on the inverter and the house power supply terminal;

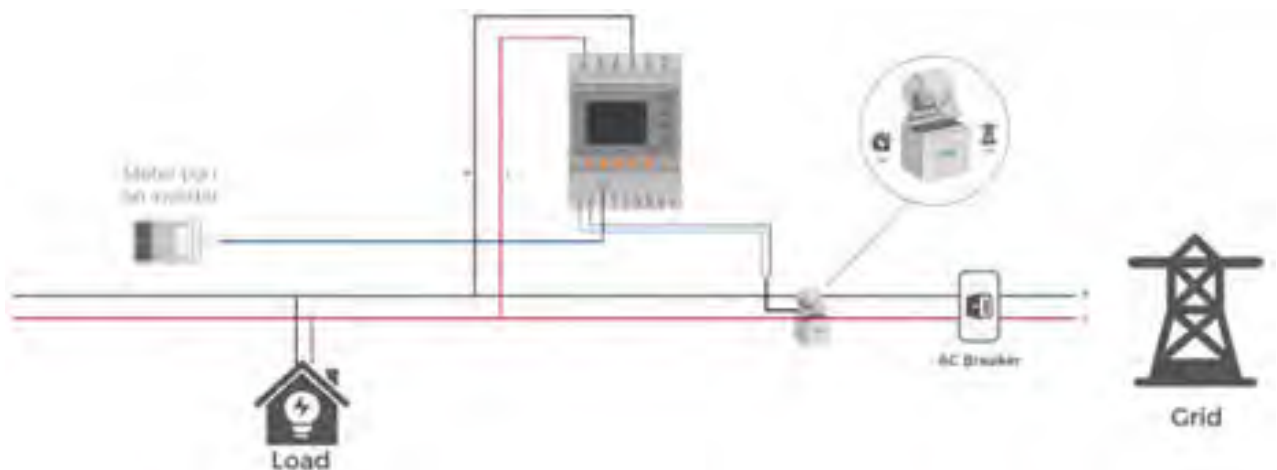

If CT is not installed or installed reversely, the functions of - -
 -
 The direction of the arrow on the CT points from this inverter to the GRID!

A Demand Response Enabling Device (DRED) can be connected to the in communication port labeled as DRM on the right side of PCS. -
 -
 steps are the same as a normal comm. cable with a connector.

To enable or disable a DRM function, please go to your

The hybrid inverter will detect and initiate a response to all supported demand response commands within [redacted] will continue to respond while the mode remains [redacted]

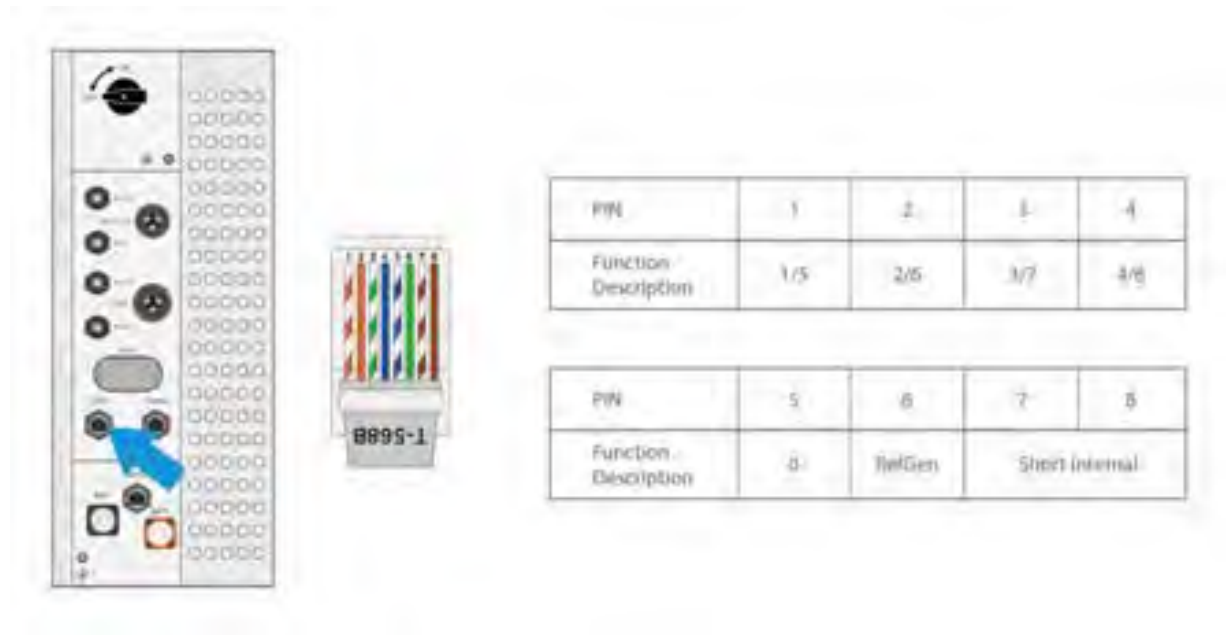

-Fi port which can collect data from inverter and transmit it

-Fi" port at the bottom of the inverter.

Build the connection between the inverter and router.

Create a user account online. (Please check the Wi-Fi user manual for more



Dongle lights on after PCS power on if it is properly connected.

After Installation Checklist

We've almost finished the installation process. Open the cable and Wi- is successful, it is time to examine power on and power off guide.

Turn on the battery breaker.



Turn on the external DC breaker.

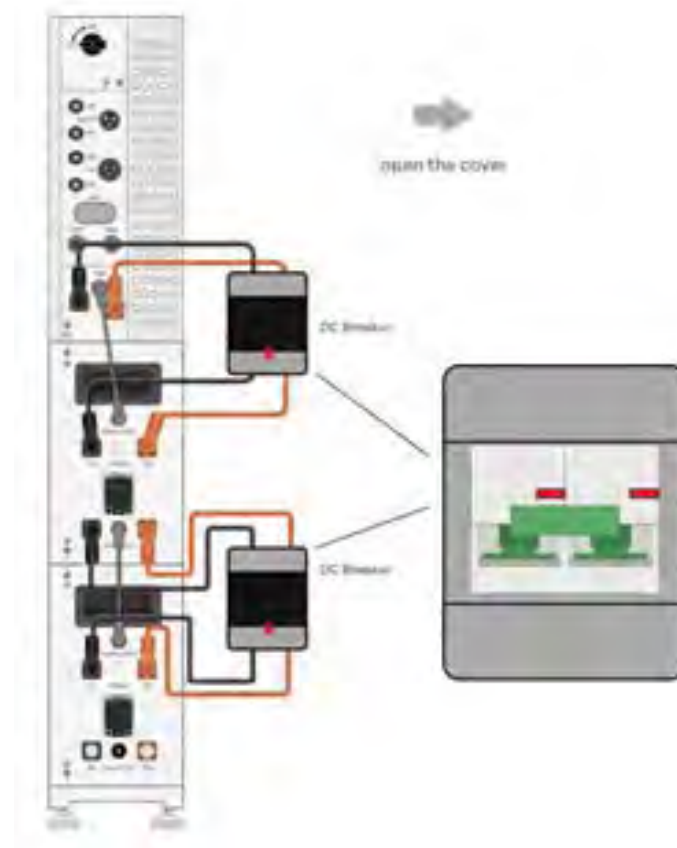

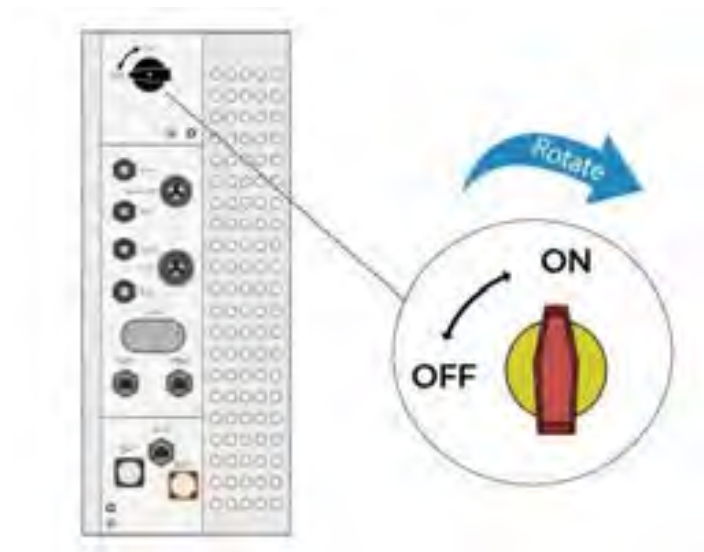

Turn on the grid breaker.

-up load is applied, turn on the backup breaker.

Configure the WIFI stick.

Make sure the WIFI connected is 2.4GHz

If the indicator is green, the system

When the DC or communication cable is improperly connected or the cable quality is poor, the indicator

Shutdown Procedure

the backup load is applied, turn off the backup load first and then turn off

Turn off the grid breaker.

Open the external DC breaker covers and turn off the breakers.

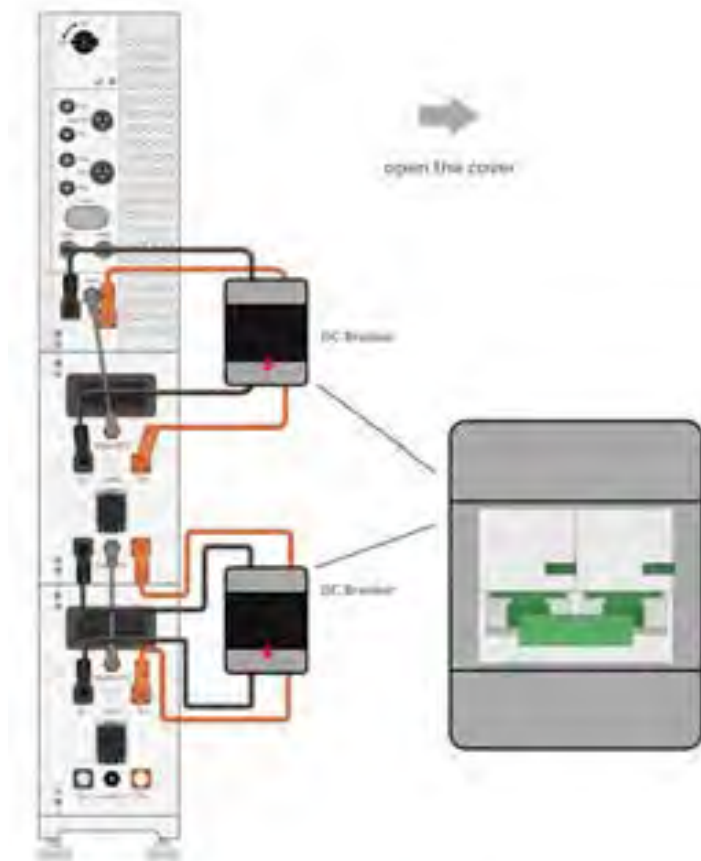

the battery breaker covers and turn off the battery breakers.

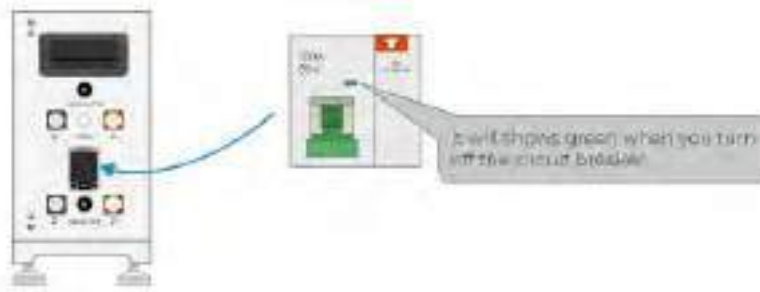

If you need to perform other operations after the power is off, use a multimeter to check whether the power is off or wait at least 5 minutes.

3 Install the LAVO Storage S2

LAVO monitoring platform supports both APP and web monitoring. Users can monitor detailed running information like generating capacity, system data, and send commands, set parameters.

Scan the QR code and
download the LAVO S2 App



Commissioning Guide
Scan the QR code and



- The APP is physically bound to the system via a Wi-Fi module installed on the inverter. Before using APP, make sure the WIFI dongle is connected.
- The customers' LAVO Life account has already been set up during the pre-

Storage and Maintenance

If the system is not to be installed immediately or removed from operation and needs to be stored for a long period, please choose an appropriate location to store

Instructions for storage are:

Keep a dry clean storage place with proper ventilation. Specifically, with a relative humidity of 5%~95% RH. If ambient temperature ranges from 20°C or 45°C to 60°C, storage period lasts for seven days. If ambient temperature ranges from 0°C to 45°C, storage period lasts for six months. The temperature of the system stored is recommended in the range of

It is not recommended to store battery modules in a warehouse. Modules should be placed not higher than 2 meters from floor. Safety deficiencies and regular modules must be stored in separate areas divided by a wall or within distinct fire protection zones. Avoid potential electrical fire hazards. Ensure electrical conduits, switch boxes, and sockets are intact. Keep a distance of 0.5 meters from floor-standing air conditioning and dehumidifiers clear of flammable materials. Opt for cold light sources in the warehouse. If spotlights are used, maintain a minimum of 1 meter distance from other flammable materials. Warehouse should be labelled with smoking ban. Smoking points should be reasonably designed with a fire-retardant wall separating warehouse. There should be no cigarette use near the warehouse, including placing of cigarette

Warehouse should have mice protective measures, like plugging up holes and using mouse expeller, floor baffler against mouse sealing door slot with less than 10mm gap.

Use fire retardant materials. Prohibit inflammable materials like plastic or canvas.

Warehouse should be equipped with fire detector, watch-surveillance video cameras and videos should be kept for at least 1 month. Module performance is vulnerable to chemical corrosion, strong acid, strong base, electrochemical corrosion, salt spray and

Do not expose the system to water.

The product box should be upright and not stacked upside down when storing the battery box.

If the battery needs to be stored for over 3 months, the main breaker of the battery is suggested to be disconnected. Otherwise, the battery would be discharged at a minimum rate and its capacity will storage time. The battery self-consumption will be less than 5W.

If the battery will be stored for over 6 months, it is suggested to connect the battery with an inverter and commission the system.

- Battery sites must be equipped with multiple varieties of battery fire extinguishers, including fire sand, blanket and power extinguishers.
- It is recommended to deploy a micro fire station with firefighter uniforms, helmets, fire protection masks, safety gloves, and at least one set of first aid kit including medical devices and drugs.

.1.2 Smoke Discharge

- Equip the room with independent fans that run 24 hours/7days and has a failure alert function. Fans should coordinate with smoke detectors or gas concentration detectors.
- The ventilation capability should not be less than 12 times per hour and wind speed should exceed 0.5 meters per second.
- Fan portfolio includes axial flow fan on wall (effective distance less than 5 meters), fan with fixed air hose, and mobile fan with flexible aluminium foil. The combination of wall fan and mobile fan is recommended.

.1.3 Fire Retardant Buildings

- Warehouse and plant should use level two fire retardant materials, such as rock wool colour steel plate, plasterboard and iron rain-
- Inflammable materials like foam and plastics are prohibited.

.1.4 Separate Storage

- Do NOT store lithium batteries with inflammable or toxic objects.
- Design various fire protection zones. Store normal modules and modules with safety deficiencies separately.

- Keep the shipment module SOC less than 30% and charge the module if it has been stored for more than 5 to 6 months.
- CC to 45A and charge the module for 1.5 hours until module terminal blocks are measured between 53.3V to 54V.

	Fully charge the battery and then discharge it to 25~50% if the
	Check the wall mounting bracket and the locking plate and fix them if they are not tight enough.
	Check whether the enclosure is broken. Repair the painting or -sales service if anything is broken.
	Check whether there is an exposed cable. Replace the exposed -sales service for help.
	Check whether there is debris accumulation around the battery to avoid affecting heat dissipation.
	Check for water and pest to avoid prolonged intrusion.
	Turn the DC switch on and off 10 consecutive times to make sure
	Check whether all the unused terminals and port are properly sealed. If not, please seal them.

Safety, Regulation & General Service

Follow local laws and regulations when installing, operating, or maintaining the equipment. The safety instructions in this document are only supplements to local laws and regulations.

LAVO battery is designed with multiple safety strategies to prevent hazards resulting from failures. However, LAVO cannot guarantee their absolute safety in

- All installation operations should be performed by trained and authorised technical personnel who are familiar with local standards and electric systems. Learn about the product before installation.
- Do not use the battery of the master box if it is defective, broken or damaged.
- Do not disassemble, modify, or replace any part of the battery or the master box without LAVO's authorisation.
- Do not hit, drag, pull, squeeze, crush, drop, penetrate on the product or give weight in any ways into any part of the battery system.
- Keep the equipment stable to avoid it falling over, which can result in equipment damage and personal injuries.
- Protect the battery system from damage during transportation and storage to meet LAVO's requirements. A the details during the transportation should be recorded.
- The battery may explode when the ambient temperature exceeds 150°C. Do not place the battery in a high temperature environment.
- -sales service immediately if the battery is unable to start. Otherwise, the battery might be damaged permanently.
- Do not move the battery system if it is connected with external battery modules. Contact after-sales service if the battery needs to be replaced.

If the battery pack leaks electrolyte, avoid contact with the leaking liquid or gas. Electrolyte is corrosive and contact may cause skin irritation and chemical burns. If one is exposed to the leaked substance, action as below:

- : Evacuate the contaminated area and seek medical attention
- : Rinse eyes with flowing water for 15 minutes, and seek medical attention immediately.
- : Wash the affected area thoroughly with soap and water, and seek medical attention immediately.
- : Induce vomiting as soon as possible, and seek medical attention

In case of a fire, make sure that an ABC or carbon dioxide extinguisher is nearby and do not use water to extinguish the fire.



The battery pack may catch fire when heated above .

If a fire breaks out where the battery is installed, action as below:

1. Extinguish the fire before the battery catches fire.
2. If the battery has caught fire, do not try to extinguish the fire. Evacuate people

If the battery catches fire, it will produce poisonous gases. Do not approach.

If the battery is wet or submerged in water, do not try to access it. Contact LAVO

If the battery is damaged, please contact LAVO for help as soon as possible. Damaged batteries are dangerous and must be handled with extreme caution. Damaged batteries are not suitable for use and may pose a danger to people or property. If the battery seems to be damaged, return it to LAVO.















Damaged batteries might export electrolyte or flammable gas, so contact for advice and information immediately and we will deal with it.



The product is designed, manufactured, and tested as per international safety standards. However, as an electrical and electric product, it must be installed, operated, and maintained strictly according to related safety notices.







If you have any problems, please contact LAVO. Please DO NOT install or repair the product by anyone who is not certified by local authority.

We are not responsible for any damage or loss caused by misuse or misunderstanding of the information in the manual.

. 1 Symbols Explanation

	The system will be touchable or operable after at least 10 disconnected, in case of any electrical shock.		product out of reach .
	Danger of high voltage and		Do not place nor install near flammable or explosive
	Danger of hot surface and burn		In case of electrolyte leakage, keep leaked electrolyte away
			Disconnect the equipment maintenance or repair.
	The wasted products must be sent to the authorised		-
	Refer to the operating		Take care! This module is heavy enough to cause serious injury.
	Danger! Serious physical injury or even death may occur if not		Observe precautions for handling electrostatic discharge

	CE mark: The inverter complies		Do not use the Pack beyond specified conditions.

	The system must be installed according to the local standards and related standards for an electrical enterprise. Please follow the instructions in this manual to use and operate the
	Keep the DC circuit breaker of PV is OFF. High voltage will be generated by the PV array exposed under sunshine. All the cables must be connected firmly.
	-) and battery negative (BAT-) are not grounded as default design. Connecting PV- - ground are strictly forbidden.
	High voltage is a hazard. Make sure the system device is away Any touch with the device or terminal may cause electric shock or fire. Please follow all the safety instructions. Damaged devices or system faults may cause electric shock. Make sure that you have checked the package and the device before installation to avoid unnecessary damage or loss.
	aware of the hot surface while the device is running.
	Do not open the inverter cover or change any components without our authorisation, otherwise the warranty commitment of the
	Comply with the local requirements for grounding the PV modules and the PV generator. It is recommended to connect the generator frame and other electrically conductive surfaces in a manner which ensures continuous conduction and ground ave optimal protection of system and

▲	<p>Ensure input DC voltage \leqMax. DC voltage. Over voltage may</p> <p>Permanent damage to the inverter or other losses, which will not be included in warranty!</p>
▲	<p>Authorised service personnel must disconnect both AC and DC power from inverter before attempting any maintenance or cleaning or working on any circuits connected to inverter.</p> <p>Do not operate the inverter when the device is running.</p>

.3 Battery Handling Guide

- Use the battery pack only as directed.
- If the battery is defective, appears cracked, broken, or otherwise damaged, or fails to operate, contact LAVO immediately.
- Do not attempt to open, disassemble, repair, tamper, or modify the battery.

The battery is not suitable for users to use by themselves.

- To protect the battery and its components from damage when transporting,
- Do not subject it to any strong force.
- Do not insert foreign objects into any part of the battery pack.
- Do not use cleaning solvents to clean the battery.
- The battery cannot be connected directly to the SELV circuit.

- CE is suggested to be installed by skilled workers or electricians.

A skilled worker is defined as a person who has been trained and is a certified electrician or qualified with all of the following skills and experience:

- Knowledge of the functional principles and operation of on-
- Knowledge of the dangers and risks associated with installing and using electrical devices and acceptable mitigation methods.
- Knowledge of the installation of electrical devices.
- Knowledge of and adherence to this manual and all safety precautions and

For scrap batteries, please deal with local laws or regulations to recycle or scrap.

Troubleshooting

Perform troubleshooting according to the following methods. Contact the after-sales service if these methods do not work. Collect the information below before -sales service, so that the problems can be solved quickly.

- Inverter information like serial number, software version, installation date,
- Installation environment, including weather conditions, whether the PV modules are sheltered or shadowed, etc. It is recommended to provide some photos and videos to assist in analysing the problem.
-

		1. The relay is abnormal or -	-
		connection or short circuit.	
		The sampling of the GFCI CT	-
			-
		The internal memory Flash is	-
			.
	-	Communication internal	-
			.

		The grounding impedance of	
		<ol style="list-style-type: none"> 1. The inverter is installed in a 2. The ambient temperature <p>internal fan of the inverter.</p>	-
		<ol style="list-style-type: none"> 1. The inverter is installed in a 2. The ambient temperature 	temperature are normal.
		<ol style="list-style-type: none"> 1. The PV voltage is too high. The sampling of the BUS 	-

		reactance to the ground is	components are properly
		The machine detects that the exceeds the normal range.	Check the components
			.
			-
			.
			-
		1. Short circuit in power grid	.
			-
			.

		connected in the series, and -	
		1. Temporary abnormality is 2. Internal components of	- .
			- .
		2. Internal components of	- .
		The utility grid voltage is out	correctly, and the neutral

			-
		The utility grid voltage is out	.
		actual grid frequency change requirement of the local grid	-

			correctly, and the neutral
			-
			-
		1. Battery input short circuit.	-
			-

			-
	-	Communication internal	-
		1. The PV voltage is too high. 2. The sampling of the BUS	-
		1. The judgment results of -	-
		Misconnection of power grid	-
			-
		The instantaneous value of charging current is too high.	-
			-
		1. The judgment results of -	-

		-	-
		BMS communication link is	-
		2. The battery voltage is too	-

. Product Parameters

	Manufacturer Information
	CSE Energy & Technology Co., Ltd
	Building S4, No. 777 Sizhuan Road, Shanghai, China
TEL	- -
E-	

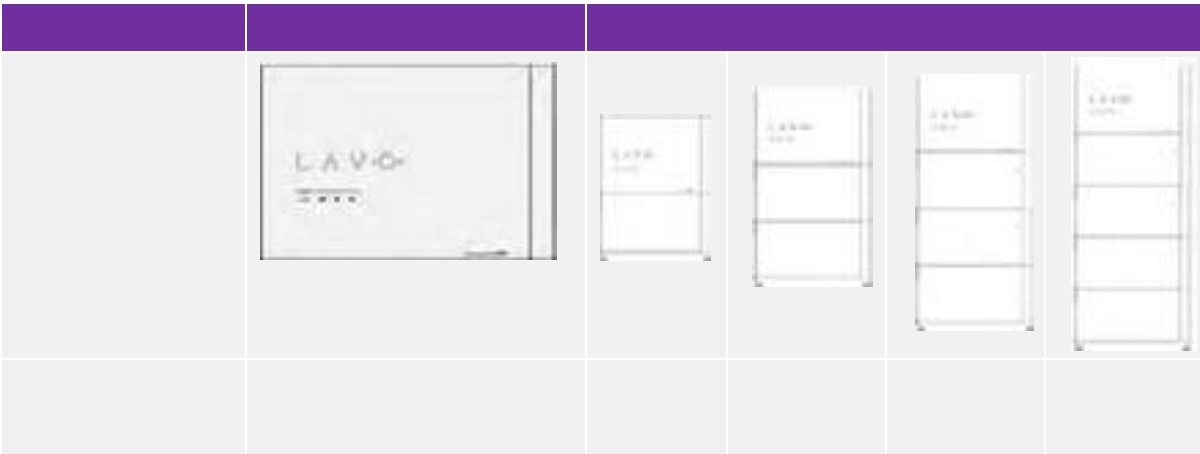

Communication with Portal	
-	
-	
	-
	°C
	- °C
	°C
	-
	-
	- -

	- -

-	
Φ	From 0.8 leading to 0.8 lagging
-	

°C	6000 Cycles/70%SOH
°C	
-	
Residual Current Detection	
-	
-	